

HEAVY DUTY FORD DANA 60 STEERING KNUCKLE

Reid Racing's high strength Dana 60 knuckles are designed to be interchangeable with Ford kingpin knuckles with exception of the Chevy style steering arm location and tie rod ends. If you use aftermarket high steer arms this will not affect your installation, but if you use the factory steering arms on your Ford knuckles you must change to the Chevy 1 ton tie rod ends and modify your tie rod and steering linkage accordingly. Although the steering arm on the Reid Racing knuckle is lower than the stock Ford knuckle, the Ford style tie rod mounts under the steering arms while the Reid Racing mounts over the arms, the actual tie rod to ground height is the same on

INSTALLATION

Remove the original knuckles from the vehicle. The original spindle studs can be removed by striking them with a soft faced hammer. New spindle studs are available from Reid Racing (part # D60102) if needed. Using a hammer and punch, tap in 5 spindle studs from the back side of the knuckle until fully seated. Slip the caliper mounting bracket on by hand and check for interference between the knuckle and the bracket. On some installations a very small amount of grinding on either the knuckle or caliper bracket to gain clearance. Install the knuckle on the vehicle according to a factory service manual making sure to torque all fasteners to the original specs.

5th BOLT HOLE

A 5th bolt hole has been added to the top of the Reid Racing knuckle for use in high steer applications. Adding the 5th stud or bolt to your high steer arms will increase the strength of your steering. Use the drawing below to determine the location of the 5th hole on your steering arms and drill a 1/2" diameter hole. Mount the arms using blue loctite on the bolts or studs and torque them to 80 ft. lbs. Re-torque after the first outing.

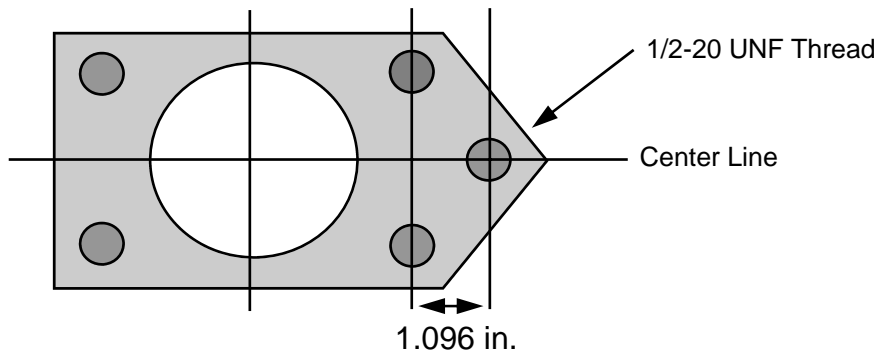

If you do not use high steer or do not want to modify 4 hole steering arms, simply do not use this bolt hole. A short 1/2" 20 bolt can be used to plug the unused hole and to keep it clean and free of debris.

NOTE: Reid Racing now stocks high strength ARP studs for mounting high steer arms. Call for details.

STEERING STOPS

The steering stops on Reid Racing knuckles are "cast in" to prevent the common bending of the stock style adjustable bolts. The stops are intentionally cast long so adjustments can be made by grinding the tips of the stops to fit. After the knuckles are installed and the toe in is set, cycle the steering back and forth grinding small amounts of the stop until the desired degree of steering is set. Make sure to check for u-joint binding and yoke to yoke interference at full lock in both directions, if binding or contact occurs, axle breakage will occur. If a stock style adjustable steering stop is desired, the cast in stop can be cut off at the knuckle then drilled and tapped for a stock 7/16" stop bolt.

WARRANTY

All "Off Road Products" sold by Reid Racing, Inc. are intended to be used for "off road" and "off highway" use only, and are NOT designed, manufactured or approved for use on any public road or highway. Due to the intended use of the products offered, all "Off Road Products" are sold without any warranties of fitness for purpose or use, merchantability, or any other kind, either expressed or implied, whether written or oral, by Reid Racing, Inc., or its past, present or future officers, directors, principals, agents, employees, legal representatives, trustees, parents, associates, affiliates, subsidiaries, division, partners, heirs, executors, administrators, purchasers, predecessors, or successors. The buyer of these "Off Road Products" bears and assumes the entire risk of loss or injury as to the fitness for purpose or use, merchantability, durability and performance of these "Off Road Products" and assumes the entire cost of any necessary maintenance, service or repair. Reid Racing, Inc. will not be liable for any subsequent, resulting or consequential damages, expenses, losses or injuries arising from or out of the use, misuse, or improper installation of any "Off Road Product".